



MV110-24.1TD

Strain gauge module

User guide

1 Overview

1.1 Functions

The module MU110-24.1TD is a 1-channel input module for resistor bridges (strain gauge). The module enables the direct connection of a resistor measurement bridge.

The module provides following functions:

- module control and parametrization via Modbus network
- RS485 network diagnostic
- sensor error indication
- Slave in the RS485 network.

The module should be configured with the “M110 Configurator” software using a RS485-USB interface adapter (not included). The latest version of the configuration software is available for download on www.akytec.de.

1.2 RS485 network

I/O modules of series Mx110 use the common standard RS485 for data exchange.

Serial interface RS485 enables communication via two-wired line in half-duplex mode.

The module supports the Modbus-RTU and Modbus-ASCII protocols with automatic protocol detection.

The network consists of a Master device and can contain up to 32 Slave devices. Maximum length is 1200 m. The number of Slave devices and network length can be increased using RS485 interface repeater.

Devices are connected to a network according to linear (bus) topology. It means that the line goes from the first device to the second one, from the second one to the third one, etc. Star connection and spur lines are not allowed.

Line reflections always occur at each of the 2 ends of the bus (the first and the last node). The higher the data transmission rate, the stronger they are. A terminating resistor is needed to minimize reflections. Line termination may be a 150 ohms value (0.5 W) resistor.

All modules can be used as Slave devices only. Master device can be PLC, computer with SCADA software or control panel.

Specifications

2 Specifications

Table 2.1 General data

Power supply	24 (20...28) V DC	
Power consumption, max.	5 W	
Measuring channels	1	
Connection circuit	4- or 6-wire	
Bridge resistance	87...1000 ohm *	
Excitation voltage	2.5 V AC/DC \pm 5%	
Warm-up time, max.	20 min	
ADC resolution **	24 bit	
RS485 interface	Connection	D+, D-
	Protocols	Modbus RTU/ASCII, akYtec
	Baud rate	2.4...115.2 kbit/s
	Data bits	7, 8
	Parity	none, even, odd
	Stop bits	1, 2
Dimensions	63 x 110 x 75 mm	
Weight	approx. 300 g	
Material	plastic	

* Four 350 ohm resistance bridges can be connected in parallel

** For measuring channel accuracy depending on strain gauge sensitivity see Table 2.2

Table 2.2 Measuring channel accuracy depending on the strain gauge rated output

Strain gauge rated output, mV/V	Measuring range, mV	Resolution, μ V	Basic accuracy, % FS
1	-4.0...+4.0	1.5	\pm 0.05
2	-7.5...+7.5	1.5	
4	-15...+15	1.5	
8	-35...+35	1.5	
16	-70...+70	2.0	
32	-140...+140	2.0	
64	-300...+300	3.5	

* Temperature drift within 10°C deviation from (20 \pm 5)°C is not greater than the basic accuracy

Table 2.3 Maximum refresh interval depending on sampling frequency

Sampling frequency, Hz	Refresh interval, ms	
	DC excitation voltage	AC excitation voltage
8.197	125	350
16.39	65	230
19.61	54	210
24.27	45	190
25.77	41	185
34.25	32	166
42.37	26	154
44.64	24	150
50.51	22	146
69.44	16	135

Specifications

Sampling frequency, Hz	Refresh interval, ms	
	DC excitation voltage	AC excitation voltage
144.9	8	120
257.7	4.3	115
409.8	3	112
588.2	2.1	110

Table 2.4 Galvanic isolation

From each group to chassis	3.0 kV
Power supply to measuring circuits	1.8 kV
Power supply to RS485 interface	1.5 kV
RS485 interface to measuring circuits	0.75 kV

2.1 Environmental conditions

The following environment conditions must be met:

- clean, dry and controlled environment, low dust level
- closed non-hazardous areas, free of corrosive or flammable gases

Table 2.5

Condition	Permissible range
Ambient temperature	-20...+55 °C
Transportation and storage	-25...+55 °C
Relative humidity	up to 95% (at +35°C, non-condensing)
IP Code	Enclosure IP20, terminals IP10
Altitude	up to 2000 m above sea level

Safety

3 Safety

Explanation of the symbols and keywords used:

 **DANGER**

DANGER indicates an imminently hazardous situation which, if not avoided, will result in death or serious injury.

 **WARNING**

WARNING indicates a potentially hazardous situation which, if not avoided, could result in death or serious injury.

 **CAUTION**

CAUTION indicates a potentially hazardous situation which, if not avoided, could result in minor or moderate injury

 **NOTICE**

NOTICE indicates a potentially harmful situation which, if not avoided, may result in damage of the product itself or of adjacent objects.

Intended use

The device has been designed and built solely for the intended use described in this guide, and may only be used accordingly. The technical specifications contained in this guide must be observed.

The module may be operated only in properly installed condition.

Improper use

Any other use is considered improper. Especially to note:

- This device should not be used for medical devices which receive, control or otherwise affect human life or physical health.
- The device should not be used in an explosive environment.
- The device should not be used in an atmosphere with chemically active substance.

Design

4 Design

- Enclosure plastic, grey, for DIN-rail or wall mounting
- Terminal blocks 2 plug-in terminal blocks with 24 screw terminals
- "POWER" LED power supply indicator
- "RS-485" LED flashes at data exchange over serial port
- "SENSOR" LED lights if sensor break or measuring channel overload

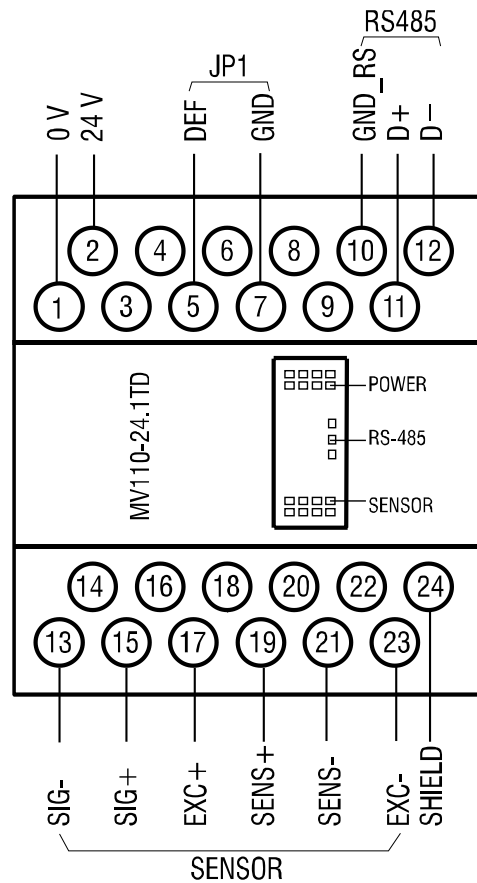

Fig. 4.1

5 Installation



Improper installation

Improper installation can cause serious or minor injuries or damage the device. Installation must be performed only by fully qualified personnel.

- The module is intended to be mounted in a cabinet on DIN-rail or on the wall. For the dimension drawings see Appendix A.
- Install the module in a cabinet with clean, dry and controlled environment. For further details see 2.1.
- The module is designed for natural convection cooling. It should be taken into account when choosing the installation site.

5.1 Wiring



Dangerous voltage

Electric shock could kill or seriously injure.

All electrical connections must be performed by a fully qualified electrician.

Ensure that the mains voltage matches the voltage marked on the nameplate!

Ensure that the device is provided with its own power supply line and electric fuse!



Switch on the power supply only after the wiring of the device has been completely performed.

- The electrical connections are shown in Fig. 4.1 and the terminal assignments in Table 5.1.
- The inputs should be wired in accordance with Fig. 5.1, 5.2.
- Connect the power supply to the terminals 24V / 0V.
- The maximum conductor cross-section for power supply is 1.5 mm².



Signal cables should be routed separately or screened from the supply cables. Only a shielded cable may be used for signal lines.

- Connect the RS485 lines to terminals D+ and D-.
- Twisted pair cable should be used for the connection to RS485 interface. Maximal cable length is 1200 m.

Table 5.1 Terminal assignments

No	Designation	Description	No	Designation	Description
1	0 V	Power supply	13	SIG-	Signal -
2	24 V	Power supply	14	NC	not connected
3	NC	not connected	15	SIG+	Signal +
4	NC	not connected	16	NC	not connected
5	DEF	Default settings	17	EXC+	Excitation voltage +
6	NC	not connected	18	NC	not connected
7	GND	Common ground	19	SEMS+	Sensor feedback +
8	NC	not connected	20	NC	not connected
9	NC	not connected	21	SENS-	Sensor feedback -
10	GND_RS	RS485 ground	22	NC	not connected
11	D+	RS485 D+	23	EXC-	Excitation voltage -
12	D-	RS485 D-	24	SHIELD	Sensor shield

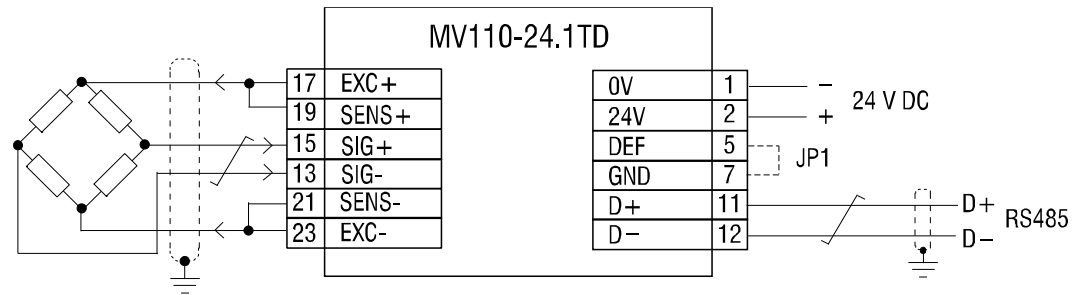

Fig. 5.1 4-wire connection

4-wire sensor connection is used when the cable length is less than 2 m. The terminals EXC (+/-) and SENS (+/-) should be bridged on the terminal block, as shown in Fig. 5.1.

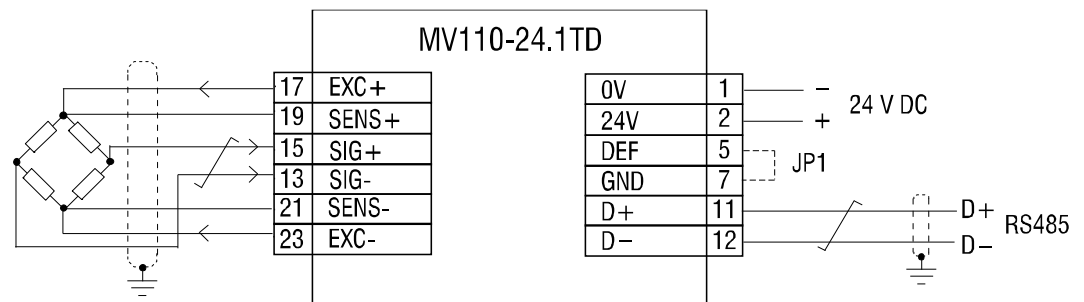

Fig. 5.2 6-wire connection

Configuration

6 Configuration

► NOTICE

Before starting

Before switching on, make sure that the device was stored at the specified ambient temperature (-10 ... +55 °C) for at least 30 minutes.

Parameters of the module can be read, edited and saved with “M110 Configurator” software (on the CD included). The full list of parameters is shown in the Table 6.1.

To control the module via Modbus network refer to Appendix B “Modbus addressing”

The module should be configured first before operating in RS485 network.

Proceed as follows:

- install M110 Configurator on the PC
- connect the device to the USB port of the PC over a USB/RS485 adapter (not included)
- connect the power supply to the terminals 24V / 0V
- turn on the device
- start the M110 Configurator.

If the factory settings of the module have not been changed, the connection to the module is automatically established, the module automatically recognized, its configuration parameters read out and an appropriate configuration mask open.

If it does not happen, parameters of the configurator should be changed.

Table 6.1 Configuration parameters

Name	Parameter	Valid value	Meaning	Default setting	Access
Basic parameters					
dev	Device	Up to 8 symbols			R
ver	Firmware	Up to 5 symbols			R
tdev	Number of channels	0	1 channel		R
Network parameters					
Bbs	Baud rate, kbit/s	0	2.4	9.6	R/W
		1	4.8		
		2	9.6		
		3	14.4		
		4	19.2		
		5	28.8		
		6	38.4		
		7	57.6		
Prty	Parity *	0	none	none	R/W
		1	even		
		2	odd		
Sbit	Stop bits *	0	1	1	R/W
		1	2		
Len	Data bits *	0	7	8	R/W
		1	8		
A.Len	Address bits	0	8	8	R/W
		1	11		
Addr	Device address	1...247		16	R/W
Rs.dL	Response delay, ms	0...255		2	R/W

Restore factory settings

- click “Connect”
- Use the menu path “Device> Check connection ...” to check the connection to the device

Table 7.1 Factory settings for network parameters

Parameter	Name	Factory setting
Baud rate, bit/s	bps	9600
Data bits	len	8
Parity	prty	none
Stop bits	sbit	1
Address bits	a.len	8
Address	addr	16
Response delay, ms	rs.dl	2

Maintenance

9 Maintenance

The maintenance includes:

- cleaning of the housing and terminal blocks from dust, dirt and debris
- checking the fastening of the device
- checking the wiring (connecting leads, fastenings, mechanical damage).

The device should be cleaned with a damp cloth only. No abrasives or solvent-containing cleaners may be used. The safety information in section 3 must be observed when carrying out maintenance.

Transportation and storage

10 Transportation and storage

Pack the device in such a way as to protect it reliably against impact for storage and transportation. The original packaging provides optimum protection.

If the device is not taken immediately after delivery into operation, it must be carefully stored at a protected location. The device should not be stored in an atmosphere with chemically active substances.

Permitted storage temperature: -25...+55 °C

► NOTICE

Transport damage, completeness

The device may have been damaged during transportation.

Check the device for transport damage and completeness!

Report the transport damage immediately to the shipper and akYtec GmbH!

Scope of delivery

11 Scope of delivery

- Module MV110-24.1TD 1
- User guide 1
- CD with software and documentation 1

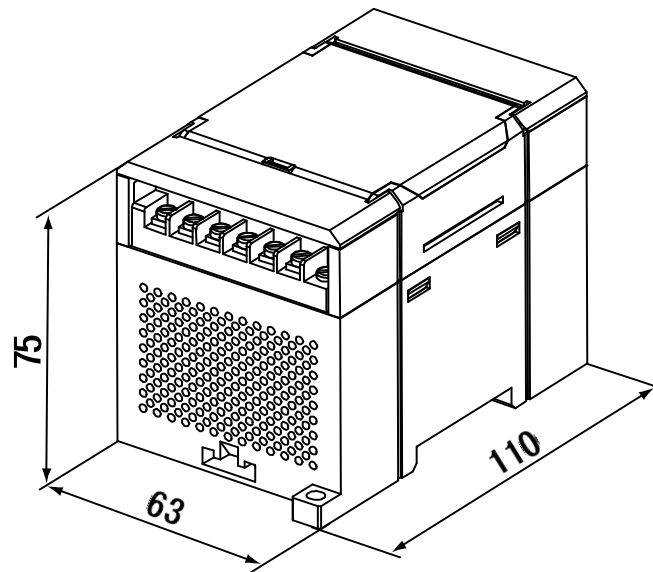

Fig. A.1 External dimensions

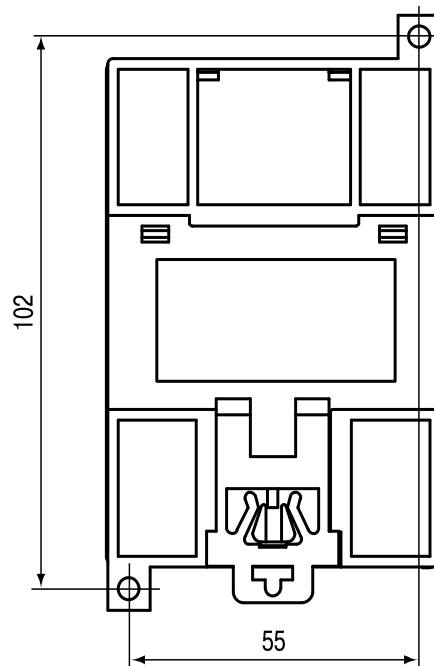

Fig. A.2 Wall mounting dimensions

Appendix B Modbus addressing

Appendix B Modbus addressing

In the operation mode the module is controlled by a network Master. The addresses from 1 to 247 can be used. The address 0 is reserved for broadcasting.

The following Modbus functions are supported:

- 03 (0x03) Read Holding Registers
- 04 (0x04) Read Input Registers
- 06 (0x06) Preset Single Register
- 16 (0x10) Preset Multiple Registers
- 17 (0x11) Report Slave ID

Table B.1 Modbus registers

No	Parameter	Register	Valid value	Meaning	Default	Access
Basic parameters						
1	Number of channels tdev	0x00	0	1 channel		R
Network parameters						
1	Baud rate, kbit/s bPS	0x01	0	2.4	2	RW
			1	4.8		
			2	9.6		
			3	14.4		
			4	19.2		
			5	28.8		
			6	38.4		
			7	57.6		
8	115.2					
2	Parity PrtY	0x02	0	none	0	RW
			1	even		
			2	odd		
3	Stop bits Sbit	0x03	0	1 stop bit	0	RW
			1	2 stop bits		
4	Address bits A.Len	0x04	0	8	0	RW
			1	11		
5	Device address Addr	0x05		0..247	16	RW
6	Last Network Error Code n.Err	0x06				R
7	Response delay, ms rS.dL	0x07		0..45	2	RW
8	Command Aply	0x08		Initializing and permanent saving of new settings	0 after executing	W
Input parameters						
1	Channel state	0x09	0	OFF	1	RW

Appendix B Modbus addressing

No	Parameter	Register	Valid value	Meaning	Default	Access
	Ch.St		1	ON		
2	Tare zero offset Cnt.P	0x0D	0	OFF	0	RW
			1	ON		
3	Strain gauge rated output Sens	0x11	0	± 1 mV/V	1	RW
			1	± 2 mV/V		
			2	± 4 mV/V		
			3	± 8 mV/V		
			4	± 16 mV/V		
			5	± 32 mV/V		
6	± 64 mV/V					
4	Lower limit v.Min	0x15, 0x16		FLOAT, Little-endian (-5x10 ⁹ ...5x10 ⁹)	0	RW
5	Upper limit v.Max	0x1D, 0x1E		FLOAT, Little-endian (-5x10 ⁹ ...5x10 ⁹)	100	RW
6	Tare weight P.Wgh	0x25, 0x26		FLOAT, Little-endian (-5x10 ⁹ ...5x10 ⁹)	0	RW
7	Tare weight multiplying P.Cnt	0x2D		USHORT (1...65535)	0	RW
8	Command U.Wgh	0x31		Use the current weight as a tare weight (P.Wgh)	0	W
9	Excitation voltage E.Rgm	0x35	0	DC	0	RW
			1	AC		
10	Command Init	0x39		All parameters are transferred to the non-volatile memory and applied (network parameters are not affected).	0	W
11	Command S.Def	0x3A		Reset of input parameters to default (network parameters are not affected)	0	W
12	Output filter length MAv.L	0x90		1..100	10	RW
2	Sampling frequency Set.F	0x91	0	8.197 Hz (50 Hz suppression)	1	RW
			1	16.30 Hz (50 Hz and 60 Hz suppression)		
			2	19.61 (60 Hz suppression)		
			3	24.27 Hz		
			4	25.77 Hz		
			5	34.25 Hz		
6	42.37 Hz (50 Hz suppression)					

Appendix B Modbus addressing

No	Parameter	Register	Valid value	Meaning	Default	Access
			7	44.64 Hz (50 Hz suppression)		
			8	50.51 Hz		
			9	69.44 Hz		
			10	144.9 Hz		
			11	257.7 Hz		
			12	409.8 Hz		
			13	588.2 Hz		
Operating parameters						
1	Measured value, mV Rd.fV	0x3E, 0x3F		FLOAT, Little-endian (-5x10 ⁹ ...5x10 ⁹)		R
2	Measured value, units Rd.fF	0x46, 0x47		FLOAT, Little-endian (-5x10 ⁹ ...5x10 ⁹)		R
3	Measured value, % Rd.pF	0x4E, 0x4F		FLOAT, Little-endian (-5x10 ⁹ ...5x10 ⁹)		R
4	Status Rd.St	0x56		INT16 (-32768...32767), see table B2		R

Table B2 Status Code (register 0x56)

Bit Number	Bit assignment	Valid value	Meaning	Comment
9	Calibration status	0	not activated	
		1	activated	
5	Calibration error	0	no error	Reset in 10 minutes after an erroneous calibration or with a valid calibration
		1	error	
1	Sensor status	0	connected	
		1	break	
0	Jumper JP1	0	set	See section 7
		1	removed	

Appendix C Calibration

Appendix C Calibration

Two kinds of calibration are available:

- user calibration provides precision scaling of the measured value
- factory calibration

► NOTICE

Factory calibration may be performed only by the manufacturer

For user calibration proceed as follows:

1. Connect the strain gauge to the device
2. Turn on the device
3. Start the “M110 Configurator” software
4. Establish the connection to the device via RS485 interface (see section 6 “Configuration”)
5. Wait for 20 minutes to warm up the device
6. Use the menu path “Tools > Calibration...”
7. Enter the access code 792 in the appeared dialog window and click “Next”
8. Select “User” as a kind of calibration and click “Next”
9. Select two points within the scaling range (from “Lower limit” to “Upper limit”) with the maximum spacing between for the calibration
10. Apply the lower selected load to the strain gauge and enter its value in physical units into the field “Lower calibration point (units)” and in percent into the field “Lower calibration point (%)”. Click “Next”
11. Apply the upper selected load to the strain gauge and enter its value in physical units into the field “Upper calibration point (units)” and in percent into the field “Upper calibration point (%)”. Click “Next”
12. Click "Save" after completing the calibration

Example:

The set measuring range:

- “Lower limit” 0 (kg)
- “Upper limit” 1000 (kg)

If 50 kg and 900 kg calibration points are selected, the calibration should be performed with following settings:

- “Lower calibration point (units)” 50 (kg)
- “Lower calibration point (%)” 5 (%)
- “Upper calibration point (units)” 900 (kg)
- “Upper calibration point (%)” 90 (%)